

Sicherheit safety



D Bitte unbedingt beachten! Die Montage dieses Erzeugnisses nur von einem autorisierten Elektrofachmann unter Beachtung der geltenden Vorschriften, v.a. auch der Vorschrift VDE 0100, Teil 701 bzw. der jeweiligen nationalen Vorschriften vornehmen lassen. Bei Nichtbeachtung erlöschen unsere Garantie- und Haftungsverpflichtungen, es kann Lebensgefahr bestehen. Das beigelegte Befestigungsmaterial ist Standardmaterial und nicht für jeden Untergrund geeignet. Zur sicheren Befestigung verwenden Sie bitte Spezialbefestigungsmaterial. Vor Beginn der Arbeiten: Strom abschalten (Sicherung !). Elektroanschluß (auf der Schrankrückseite): Muss in einer Wandanschlußdose erfolgen - siehe Bild Klemme: z.B. Adels Typ 500). Die Mantelisolierung des Anschlußkabels muss dabei bis in die Dose hineinführen. Einzelleitungen dürfen keinesfalls eine metallische Rückwand (z.B. Alutapete) berühren können. Schutzleiter des Spiegelschranks (grün/gelb) mit dem Schutzleiter (grün/gelb) der Netzleitung verbinden.

Die Anschlußleitung darf nicht gequetscht werden. Nach der Wandmontage unbedingt festen Sitz des Schrankes auf den Haken prüfen ! Schutzbereich um Badewanne und Dusche beachten (Mindestabstand: 60 cm). Lampe auf der Oberseite nicht abdecken ! Defekte Leuchtstofflampen gehören nicht in den Hausmüll, sondern müssen unzerstört gesondert entsorgt werden (Sondermüll).

GB Essential points: This unit may only be installed by an authorised and qualified electrician in conformance to the established regulations (GB: BS 7671). Any violation of this requirement will invalidate our warranty and liability obligations and may endanger life. The enclosed mounting material is standard and not suitable for every base. Please use special mounting material to ensure that the unit hangs securely. Turn off the electricity before beginning. Electrical connection (on the rear of the cabinet): must be led into a wall connection socket (fig.). The external insulation on the connection cable must extend into the socket. It is essential to ensure that single conductors cannot come into contact with any metal (e.g. aluminium wallpaper, metal tubes...). The protective earth conductor (green/yellow) on the mirror cabinet must be connected to the protective earth conductor (green/yellow) in the mains cable! The connection lead may not be pinched. Once the cabinet is affixed to the wall, it is essential to make sure that it hangs securely. Leave a safety area around the bath and shower (minimum distance of 60 cm). Do not place anything on the top of the cabinet. Defective fluorescent lamps do not belong in the household refuse, but must be disposed of separately (undestroyed with the special refuse).

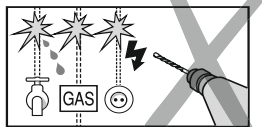

Pflege, Reinigung, Garantie

Pflege, Reinigung: Oberflächen nur mit einem feuchten Tuch reinigen, evtl. milden Allzweckreiniger verwenden. Keine scheuernden oder lösungsmittelhaltigen Reinigungsmittel oder scheuernden Schwämme benutzen. Alu-Schränke: keine Säuren! Kristallglasspiegel nur mit einem weichen Tuch reinigen. Hartnäckigen Schmutz hier mit klarem Wasser und ausgewrungener Leder beseitigen. Bitte für Spiegel niemals chemische Reinigungsmittel verwenden.

Garantie: Für unsere Erzeugnisse gewähren wir ab Verkaufstag eine Garantie von 2 Jahren. Ausgeschlossen von dieser Garantie sind Schäden durch nicht fachgerechte Montage, unsachgemäße Behandlung sowie Verschleißteile wie Lampen und Starter. Bei Reparaturen bitte nur Originalteile verwenden, Elektroreparaturen nur vom Elektrofachmann ausführen lassen, keine Änderungen am Erzeugnis vornehmen ! Ansonsten müssen wir jede Haftung ablehnen, der Garantieanspruch geht verloren. Unser Kundendienst hilft Ihnen bei Problemen. Für Hinweise und Anregungen sind wir immer offen.

Änderungen und Irrtümer vorbehalten.

Care, cleaning, guarantee

Care and Cleaning Only use a damp cloth to clean the surfaces, if necessary with a mild all-purpose cleaning liquid. Do not use any scouring detergents, detergents that contain solvents or abrasive sponges. Aluminium cabinets: no acids! The crystal glass mirror may only be cleaned with a soft cloth. Remove stubborn dirt with clear water and a wrung-out chamois leather. Please never use chemical detergents on the mirrors.

Guarantee: We guarantee our products for 2 years from the date of purchase. Damage caused by improper handling or incorrect installation and expendable parts such as bulbs and starter switches are excluded from the guarantee. Only genuine parts may be used for repairs. Electric repairs may only be done by qualified electricians. Do not make any alterations to the product. Otherwise, we shall cease to be liable and warranty claims will not be accepted. Our customer support will help you have any problems. We are always grateful for information and suggestions from customers.

Subject to alterations. Errors excepted.

Bei Reklamationen diesen Abschnitt (Kopie) **zusammen mit dem Kaufbeleg** an Jokey schicken. If there is a problem send this coupon (or copy) **together with the receipt** back to Jokey.

QS

→ Jokey Service

430713744

19 110 Entro / 03_2 / 2013

Jokey Plastik Sohland GmbH Service Industriestr. 4 D - 02689 Sohland / Spree
Tel.: +49(0)35936 / 36-0 Tel. Service: +49(0)35936 / 36-2265 email: js.service@jokey.com
Fax: +49(0)35936 / 36-2222 Fax Service: +49(0)35936 / 36-2281 http://www.jokey.com







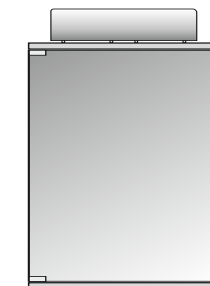
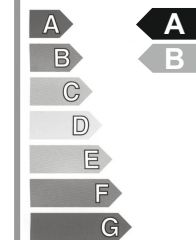



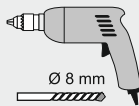
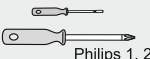
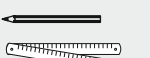

E27 ESL 15 - 23W

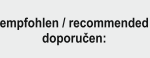
Ενεργειακή Λάμπα

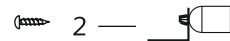

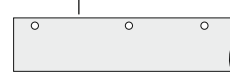
ENTRO

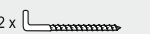
19 110

		Befestigungsteile - jetzt bereits vormontiert.	 Ø 8 mm  Philips 1, 2   
C	8 x		
D	2 x		
E+F	4 x + 4 x		
V	1 x		empfohlen / recommended / doporučen: 2 x  ø8 x 40-50 Polyamid 2 x  ø5-6 x 60
G+H	2 x + 2 x		Separater Spiegel nur bei Versand / postal shopping:

SCHUTZBEREICH / SAFETY AREA



F	Zone de protection	RO	Domeniu de protecție
TR	Korunma bölümü	SLO	Zaščitno območje
RUS	Защитная зона	I	Zone de protezione
NL	Veiligheidsruimte	HR	Zaščitno područje
PL	Strefa ochronna	E	Zone de protecção
CZ	Ochranné pásmo	P	Zona de protecção
SK	Ochranné pásmo	DK	Sikkerhedsafstand
H	Védett terület	FIN	Turva-alue
BG	Зашитен участък	GR	Περιοχή προστασίας

Minimum: 60 cm

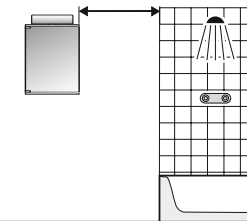

Empfohlen / recommended / doporučen:

Energiesparlampe / Energy saving lamp 15...23 W E 27
 Color: 840, 4000K = universal / weiß / white / bílý
 827, 2700K = warmweiß / warmwhite / teplý =
 z.B. 20W, 1200 lumen, = 95W ⚡, Life: 6000-12000h,



E27, max. 25W !

Recycling: 

Entro 19 110

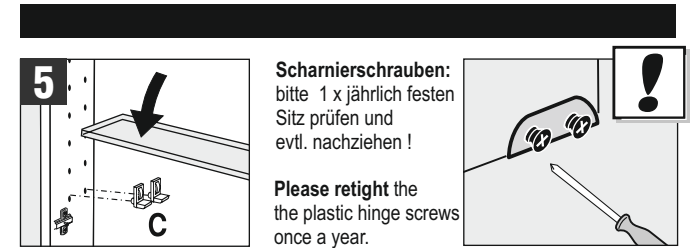
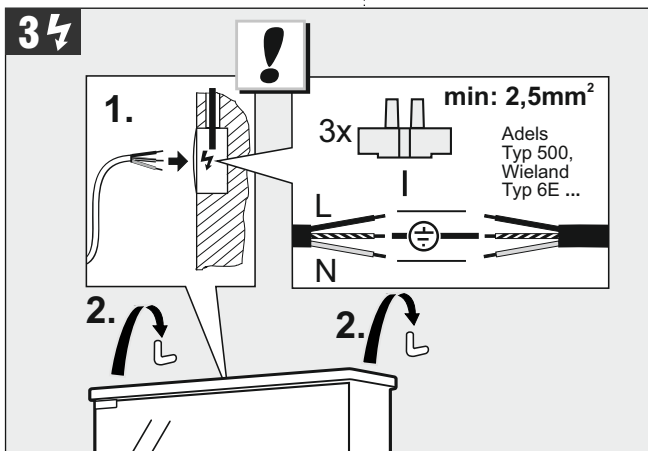
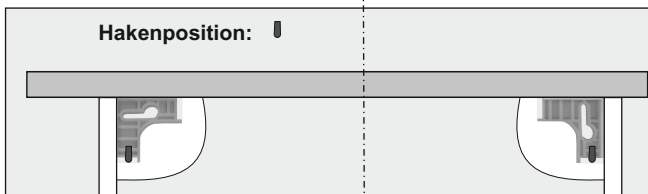
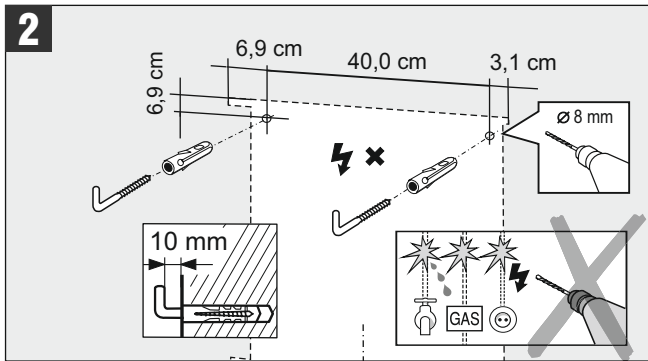
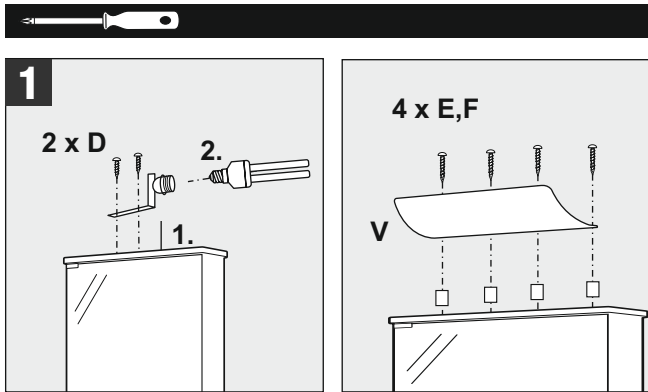
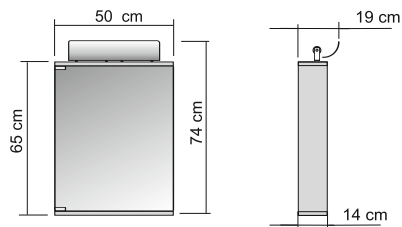

Nur bei Versandhandel (Spiegel separat verpackt) / postal shopping :

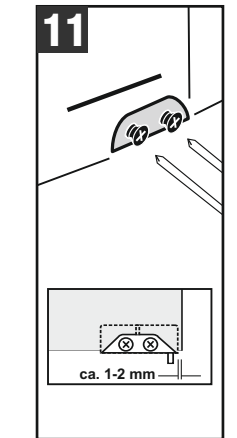
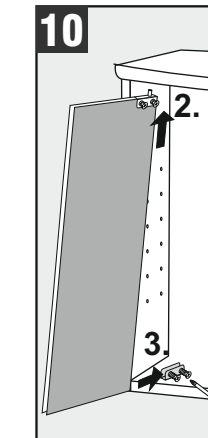
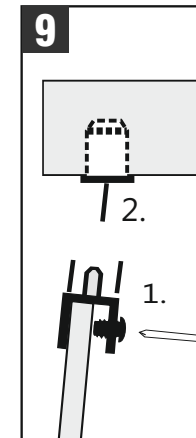
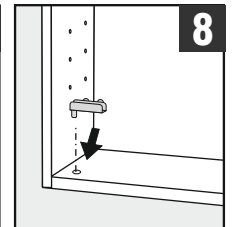
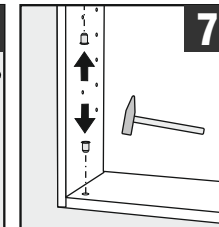
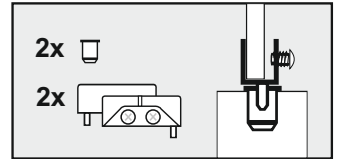

ERSATZTEILE / SPARE PARTS

F	Pièces d'échange	RO	Piese de schimb
TR	Yedek parçalar	SLO	Rezervni deli
RUS	Запасные части	I	Pezzi ricambio
NL	Onderdelen	HR	Pričuvni dijelovi
PL	Części zamienne	E	Piezas de recambio
CZ	Náhradní díly	P	Piezas sobresselentes
SK	Náhradné diely	DK	Reserveudete
H	Tartalék részek	FIN	Varaosat
BG	Резервни части	GR	Ανταλλακτικά

